

## REAMP: HIGH ACCURACY POWER CONSUMPTION LOGGER

### TO EASE THE LIFE OF IOT DEVELOPERS

When you want to get the longest battery life possible, you need a high accuracy and reliable power measurement tool.

So REAMP is the best choice for your Ultra Low Power projects and IoT developments. REAMP measures ultra-low current and voltage and functions as a highly stable and accurate power source for Device Under the Test (DUT).

It allows you to see even subtle changes in the power consumption profile of the DUT



#### FEATURES:

- Wide range and high accuracy Current measurements (from 10 $\mu$ A to 1A)
- Two channels for Voltage measurement (0V to 5V)
- 10 Hz to 10 kHz Sample rate
- TRIG and SYNC gates to synchronize logger with target board and PC
- Time-limit and infinite measurement modes
- Built-in Li-Ion battery for cases when DUT current consumption is over 500 mA
- Comprehensive power consumption analysis with REAMP PC Software (diagrams, data recording, saving data log files)
- Easy navigation both for small or extremely large measurement data sets, zooming and scrolling features
- Consumption averaging as well as real-time analysis
- Battery Life Calculator
- Ready-to-use Multi-OS software for Windows<sup>®</sup>, Linux<sup>®</sup> and macOS<sup>®</sup>

*USE REAMP IN YOUR ULP DIY PROJECTS TO ACHIEVE MORE AND SUCCEED FASTER*

## 1. INTRO

The REAMP POWER CONSUMPTION LOGGER (REAMP) is designed to test the power consumption modes of various devices powered by 1.8V to 5V DC. It can also supply voltage to the device under test within a wide selection range of 1.8V to 5.2V with a 50mV step.

REAMP allows users to measure instantaneous values of the consumption current and voltage, record them in a log file, mark the signals amplitude, determine the signal period, perform values average over a specified time interval, calculate the duration of an autonomous source DUT operation, control data recording, and report data in graphical and tabular forms (\*.xlsx, \*.CSV). Users can also work with archived log files and more.

The current measurement range is 10 $\mu$ A to 1A (100dB) and there are two input channels for voltage measurement at the user's DUT points of interest. The range of voltage measurement is 20mV to 5V. The sampling frequency is 10 Hz to 10 kHz.

This device is particularly useful for developers of IOT, USB, and other devices where minimizing power consumption during sleep mode is crucial. It is powered and operated when connected to a computer via a USB port.

## 2. FUNCTIONAL DIAGRAM AND CONNECTION

Functional and connection diagram of REAMP device is shown on Figure 2.1.

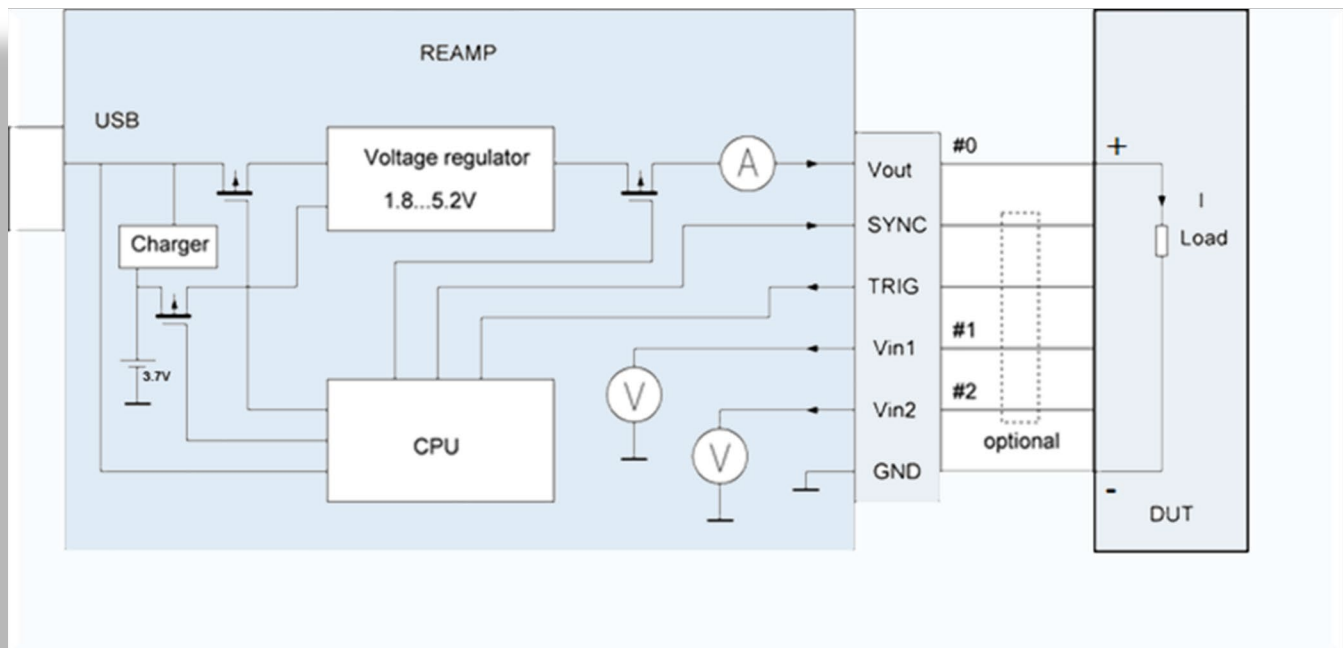

FIGURE 2.1: FUNCTIONAL AND CONNECTION DIAGRAM

**Connector pin assignments:**

- DUT — device under test
- $V_{out}$  — + 5 V (1.8...5.2 V), current measurement channel
- SYNC (optional) – output is flag for synchronization of the external device operation with the measurement starting process ("1" - start of measurement, "0" - stop of measurement)
- TRIG (optional) —input is flag from the external source for the measurement start ("1" - start of measurement, "0" - stop of measurement)
- $V_{in1}$  — 1<sup>st</sup> voltage measurement channel
- $V_{in2}$  — 2<sup>nd</sup> voltage measurement channel
- GND – ground

**3. PREPARING FOR MEASUREMENTS**

A 6-position connector (Fig. 2.1) on the REAMP front panel is connected to the DUT by test probes included in the kit.

**To measure the current:**

- 1) Connect  $V_{out}$  of REAMP to positive ("+") bus of power supply lines of DUT and connect GND of REAMP to negative ("-") bus of power supply lines of DUT
- 2) Run the REAMP program on your PC, which is compatible with Windows, Linux, and MacOS operating systems. The program can be downloaded on your PC from <https://rigexpert.com/files/software/ReAmp/>
- 3) Connect REAMP to your PC with a TYPE A–TYPE B USB cable
- 4) The circuit is now ready for measurements using the user interface of the REAMP program. Installation instructions for the REAMP program can be found in section 4.

**To measure the voltage:**

- 1) Connect  $V_{in1}$  and/or  $V_{in2}$  of REAMP to the positive ("+") input of measurement point (controller/processor/sensor/device under test) and connect GND of REAMP to the negative ("-") input of measurement point
- 2) Run the REAMP program on your PC, which is compatible with Windows, Linux, and MacOS operating systems. The program can be downloaded from <https://rigexpert.com/files/software/ReAmp/> on your PC
- 3) Connect REAMP to your PC with a TYPE A–TYPE B USB cable
- 4) The circuit is now ready for measurements using the user interface of the REAMP program. Installation instructions for the REAMP program can be found in section 4.

The DUT can be powered from the REAMP. The two connections are required for its operation:  $V_{out}$  to "+" DUT and GND to "-" DUT. This setup allows for measuring the current consumption of the DUT.

Since a USB port can only provide up to 500 mA of current output, the REAMP is equipped with a built-in Li-ion battery to ensure sufficient power. The battery is automatically recharged through a USB port using a charge algorithm of CC-CV at 250 mA current. When the battery is fully discharged (below 3 V), the power source will switch to the USB for recharging.

It's important to note that while the battery is being charged, a portion of the USB port's current will be used for this purpose, leaving only the remaining portion of the total 500 mA current available for powering the DUT.

The REAMP contains an internal overload protection circuit that limits the output current to:

- 0.5 A when powered via a USB
- 1.5 A when powered by a battery.

#### 4. INSTALLATION OF REAMP LOGGER SOFTWARE

Use <https://rigexpert.com/files/software/ReAmp/> to download and install the REAMP Logger software for Windows OS/Linux OS/ MacOS.

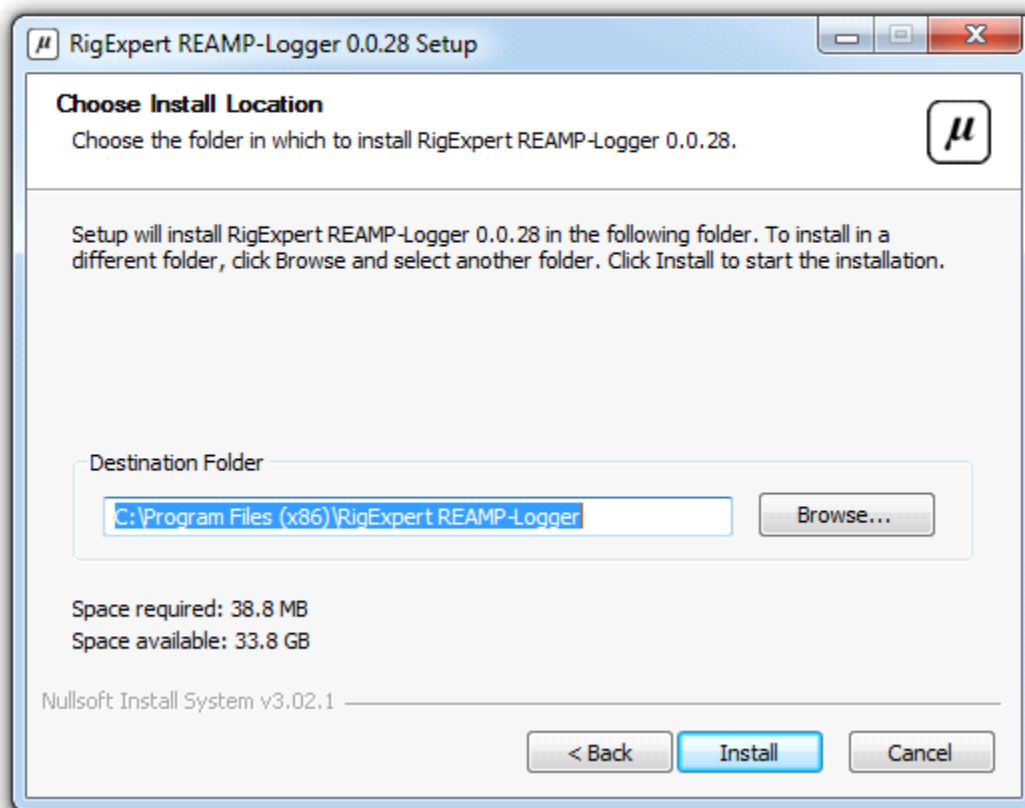

FIGURE 4.1: SW INSTALLING

- Please double click on REAMP setup icon, then press NEXT
- Select the destination folder and press Install
- Run REAMP program on your PC
- Connect REAMP Logger to a USB port of your PC
- Wait until USB HID drivers are automatically installed
- Launch SW REAMP Logger and check the main window (see Fig.4.2).

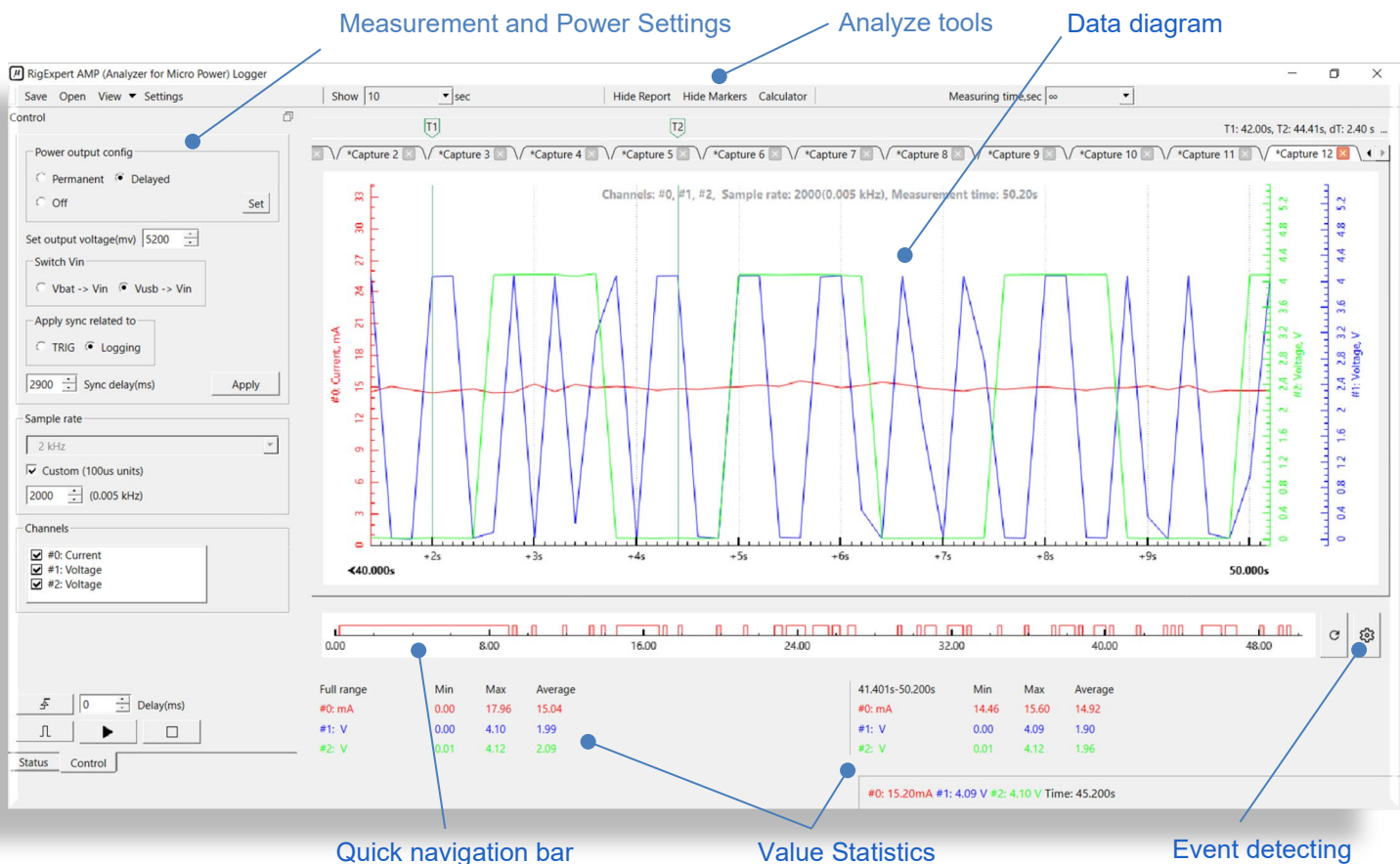

FIGURE 4.2: MAIN WINDOW

### Quick navigation bar for finding event/points

When dealing with a large data file, the event detector helps to identify and analyze peaks. By setting the peaks threshold, you can view anomalies and click on them in the Navigate bar to directly access the corresponding measurement segment. To zoom, hold the left mouse button and highlight the zoom area on the scale with the cursor. To reset the zoom, simply click **C**.

### ZOOMing data on the data diagram

To zoom, position the cursor on the measuring axis and use the mouse wheel to adjust the zoom level. Double-clicking the axis will return it to the default scale.

You can also use the mouse to select a specific portion of data for a closer view.

**Quick navigation bar and ZOOMing works in data analyze mode when active measurement is stopped.**

## 5. BASIC OPERATION

### The device has two operation modes:

- Logging mode - takes instantaneous measurements and records them in a log file. In this mode, configuration and control functions (except for the "STOP" button) and "Show Report" are not available
- Data analyze mode - allows viewing recorded information, saving log files, time scaling, calculating the discharge time of the DUT battery for a given current time consumption profile, and operating with historical data (log files)

Converter mode - enables the conversion of saved log files to table format (\*.xlsx or \*.CVS) using the REAMP converter application from the installed REAMP-logger package.

**To start working in measurement mode:**

- Connect the DUT to REAMP as shown in diagram (Fig. 2.1.)
- Run the REAMP-logger on your PC
- Connect the REAMP to the PC
- Set power voltage (mV)
- Make settings in accordance with subsections 5.1-5.4.

**To use analyze mode** in REAMP logger, open the saved files or stop the measurement mode. The data analysis program functions are described in subsections 5.5.

**To convert data**, pen REAPM-converter, select the log file on the PC, choose the desired output format and time format, then click "Start".

## 5.1. POWER CONTROL

Set output power voltage (Figure 5.1).

If the DUT consumes the current less than 500 mA, then select option "Vusb → Vin" in the "Switch Vin" field, otherwise select "Vbat → Vin".

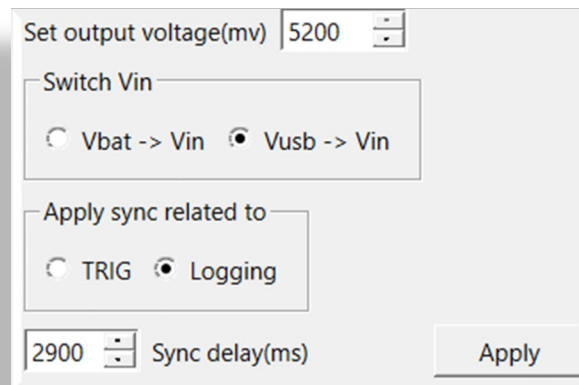

FIGURE 5.1: VOLTAGE SETS

To delay the start of power or logging select the desired delay in the "Sync related" field and choose either TRIG or Logging. If you don't need a delayed recording or power supply, enter 0 in the "Sync related" field and then click "Apply".

After that, you can choose the type of power supply: Permanent for immediate power to the device under test (DUT) or Delayed for a delayed power supply (refer to Figure 5.2).

Once you've made your selection, click "Set" and the power supply will be provided to the DUT.

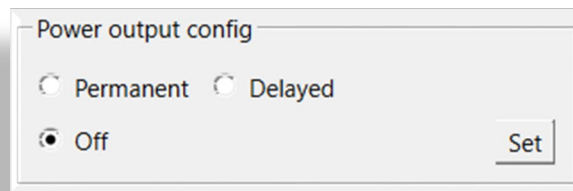

FIGURE 5.2: POWER SETS

## 5.2. SYNC CONTROL

This function is designed for specific measurements when necessary.

The "SYNC" field is displayed in Figure 5.1.

Configuration of SYNC should be done before starting the measurement or after pressing the "STOP" button.

You can choose the power source: either USB or battery.

Set the output voltage within the range of 1800mV to 5200mV.

To apply a voltage to the DUT, you have two options:

- Keep it always on
- Start with a delay linked to the measurement process. The delay time is 100 measurement samples but no more than 100ms—refer to Figure 5.3.

Press the Apply button to activate the new settings.

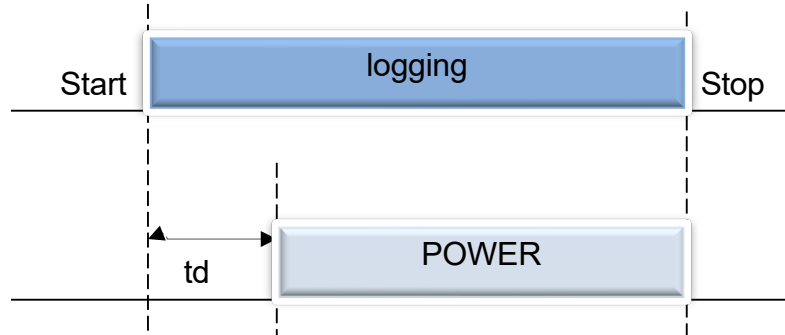

FIGURE 5.3: DELAYED POWER SUPPLY

This mode helps monitor unusual spikes in power usage when the Device Under Test (DUT) is powered on.

## 5.3. APPLYING OF TRIGGER-SIGNAL WITH SYNCHRONIZE-SIGNAL

In certain cases, when studying the DUT sleep modes, it may be necessary to trigger measurements synchronously (or with a specific delay) with a process taking place in the DUT circuit. Or vice versa, the gauge must trigger a process synchronously (or with a delay) relative to the start of measurements. For this purpose, the REAMP device has TRIG and SYNC signals.

### 5.3.1. TRIGGERING (TRIG) SIGNAL

This function is for specific measurements, if it's needed.

Configuring of TRIG should be before measurement starting or after "STOP" button is pushed.

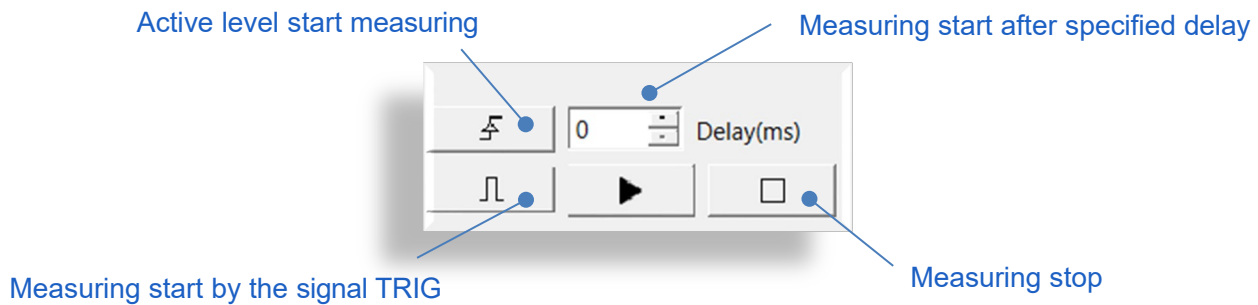

FIGURE 5.4: TRIG CONTROL

TRIG signal. Input.

The acceptable signal levels are:

Low (LOW):  $U < 1$  V.

High (HIGH):  $10$  V  $> U > 2.5$  V. The active level is HIGH.

It allows an external source to trigger the measurement process. Three modes are available:

1. The active level triggers the measurement, the user stops the process arbitrarily.
2. The active level triggers the measurement after the configured delay, the user stops the process arbitrarily.
3. The measurement is triggered and stopped by a signal— see Figure 5.5.

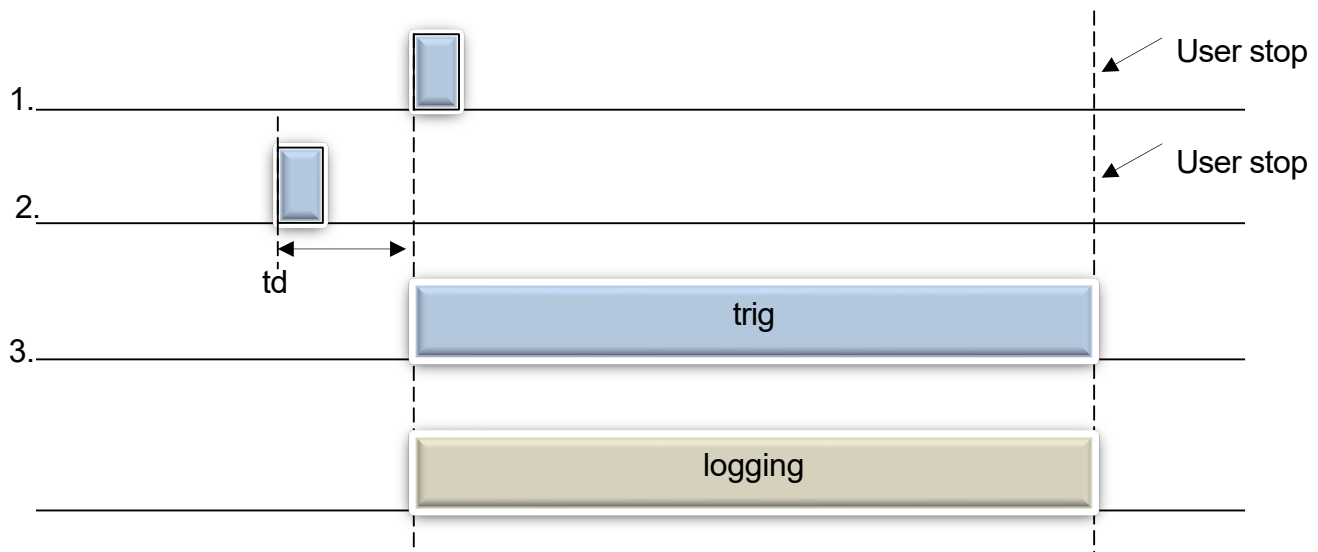

FIGURE 5.5: TRIG MODES

### 5.3.2. SYNCHRONIZATION (SYNC) SIGNAL UNDER TRIG CONTROL

Settings of SYNC signal is shown on Figure 5.6.

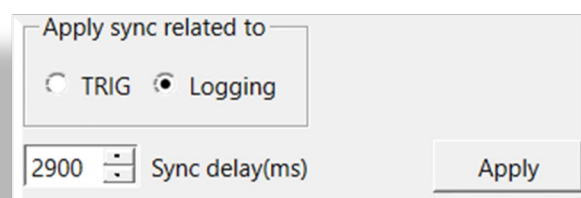

FIGURE 5.6: SYNC SIGNAL SET



SYNC signal. OPEN-DRAIN output. The levels acceptable for this signal are: Low (LOW):  $U < 1 \text{ V}$ .

High (HIGH):  $U_{\text{up}} > U > 2.5 \text{ V}$ .

The active level is LOW. It enables synchronization of the external process with the measurement triggering process. Two modes are available:

1. Linked with the TRIG signal. Activated with a preset delay by the TRIG signal. Deactivated at the end of the measurement.
2. Linked with the measurement process. Activated with a preset delay after the start of the measurement and deactivated at the end of the measurement— see Figure 5.7.

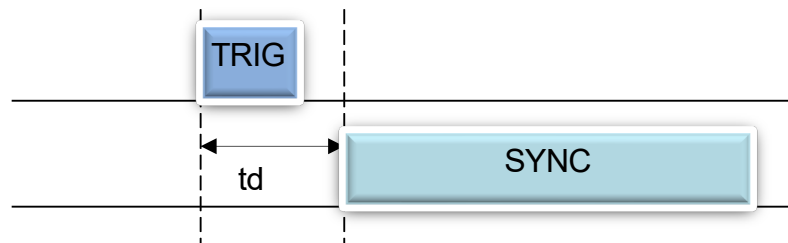

FIGURE 5.7: SYNC MODES

#### 5.4. OPERATION IN THE MEASUREMENT MODE

The measurement mode (logging) is the REAMP device operating mode which allows instantaneous sampling of the measured value, digitizing, displaying as a graph on the screen, and saving to a log file.

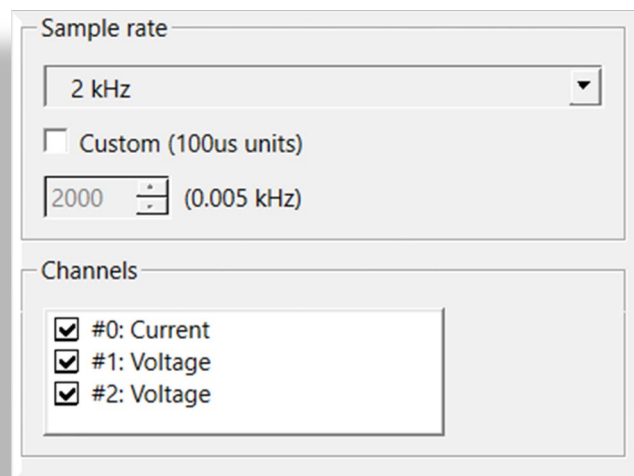

FIGURE 5.8: MEASUREMENT SETTINGS

Elements of the measurement panel (Figure 5.8):

1. Set the sampling frequency in kHz. The maximum sampling frequency of 10 kHz is available only when using a single-channel gauge.
2. Set the sampling frequency in  $100 \mu\text{s}$  units.
3. Select a channel to be logged. Correspondence between REAMP measuring channels and channels for display/logging in the REMP-logger program:

- Channel #0 – Vout (Current)
- Channel #1 – Vin1
- Channel #2 – Vin2

4. Settings are complete. Ready to start measuring.
5. Press "Start" to begin the measurement (Figure 5.9).

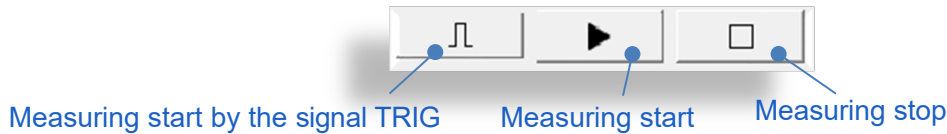

FIGURE 5.9: START AND STOP BUTTONS OF MEASUREMENT

1. Press "STOP" (Figure 5.9) for measurement ending. Each new measurement is performed in a new tab. Each tab can be saved in separated log file. All settings are available only in the stop condition.

### 5.5. OPERATION IN THE DATA ANALYZE MODE

In this mode, you can change REAMP settings and measurement parameters, switch between tabs, save measurement results, operate with previously saved log files, navigate through the log.



FIGURE 5.10: DATA ANALYZE MODE

- MTI (measuring time interval). Set T1 and T2 to specify the duration for taking measurements.
- Measurer panel. Shows the average current and voltages at the DUT control points, as well as the input voltage powering the REAMP (USB or battery).
- Mouse hints. Displays the values of measurable parameters at the point/location on the graph, to which the mouse pointer is moved.
- Report bar. Visible when the “Hide report” button isn’t active. Displays the maximums, minimums, and averages of the measurable values in the measurement period.
- Navigation bar is displayed the entire logging interval and allows setting (press "Setting sign" on the left of navigation bar) threshold values for each channel of measurable parameters. Clicking on a point in the navigation bar shows it in the main data diagram.
- Data diagram. Can be scaled horizontally and vertically by highlighting an area with the left mouse button or using the scroll wheel. To reset zoom, double-click on the axis.

### 5.5.1. ADDITIONAL TOOLS

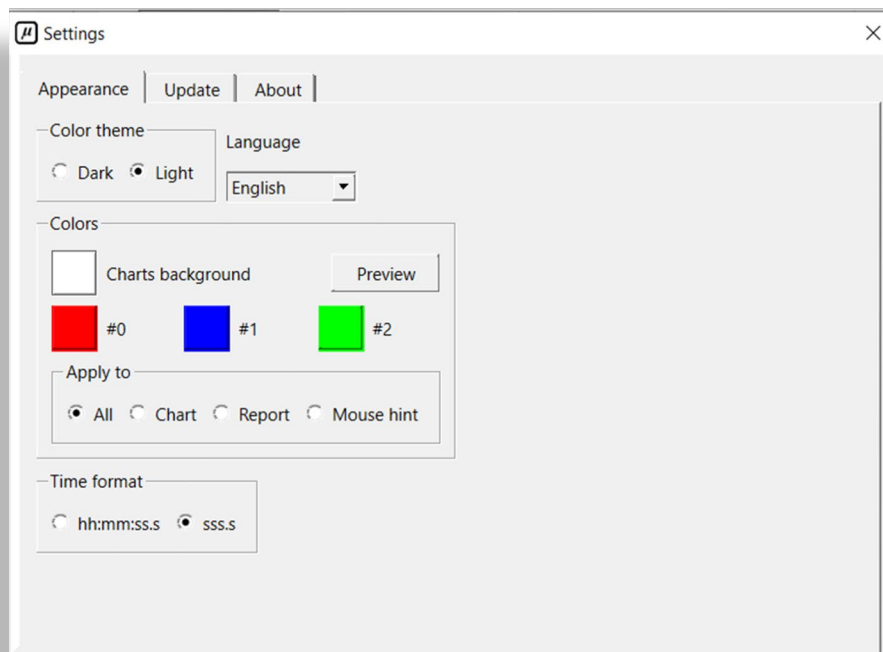

Additional settings can be made by calling Settings on the toolbar (Figure 5.11).

FIGURE 5.11: SETTINGS MENU

## 6. REAMP FW AND SW UPDATE

REAMP firmware can be updated by REAMP-logger program (see Figure 5.12) or by RigExpert Flash Tool ( <https://rigexpert.com/files/software/FlashTool/>)

REAMP-logger software is updated as shown in Figure 5.12 or by [rigexpert.com](http://rigexpert.com).

Select Settings → Update - See Figure 5.12

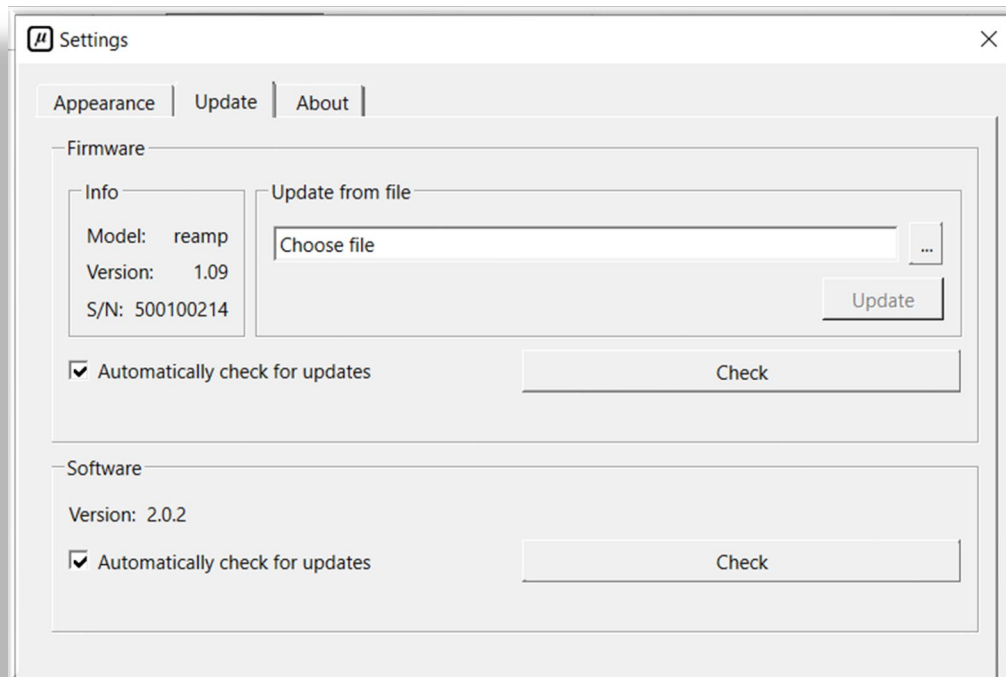

FIGURE 5.12: UPDATE OF REAMP FIRMWARE AND SOFTWARE

- Select file.
- Press the “Update” button.

SPECIFICATIONS	
Number of measuring channels:	3
Measuring range:	<ul style="list-style-type: none"> <li>• Current – 10µA to 1A (1 channel)</li> <li>• Voltage – 0V to 5V (2 channels)</li> </ul>
Sample rate:	10 Hz...10 kHz (10 kHz one channel only)
Measuring results displaying:	<ul style="list-style-type: none"> <li>• Instant values graph</li> <li>• Average values in digital format</li> <li>• Saving data to a log</li> <li>• Easy navigation using horizontal and vertical zooming</li> </ul>
Power supply:	<ul style="list-style-type: none"> <li>• PC USB port</li> <li>• Additional built-in Li-ion battery to be used when current consumption is over 500 mA</li> </ul>
Interface:	<ul style="list-style-type: none"> <li>• USB connection to a PC (USB 2.0, USB 3.0)</li> <li>• Operation system Windows 7, Windows 8, Windows 10.</li> <li>• Application software “REAMP Logger”</li> <li>• 3 languages support (EN, UA, RU)</li> </ul>
Dimensions:	67 mm x 57 mm x 27 mm
Operation temperature:	0...40 °C
Weight:	100 g
Warranty:	2 years

**\* All specifications are subject to change without notice or obligation.**

Copyright © Rig Expert Ukraine Ltd.

“RigExpert” is a registered trademark of Rig Expert Ukraine Ltd.

REAMP Logger made in Ukraine.

[rigexpert.com](http://rigexpert.com)

**RigExpert**